

POMPA ELETTRICA

EL60

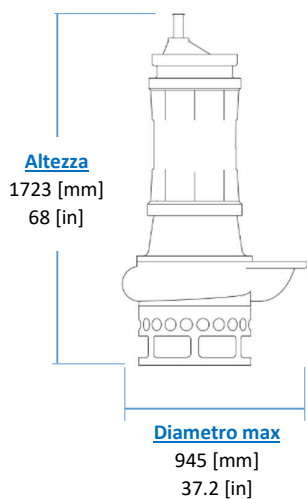
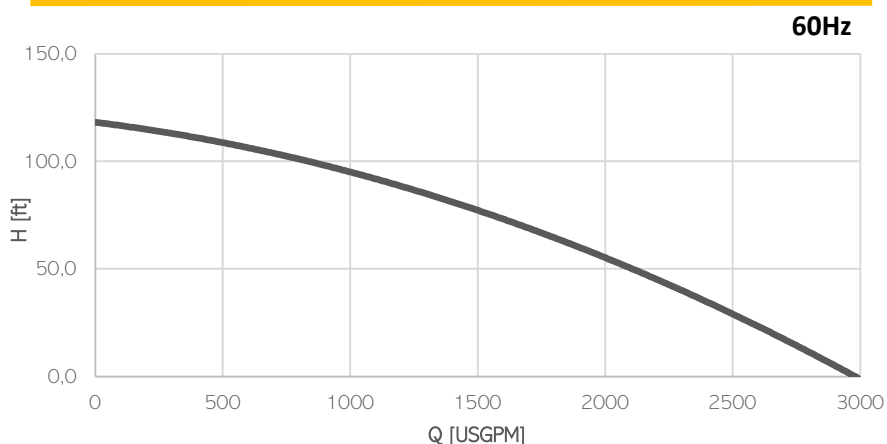
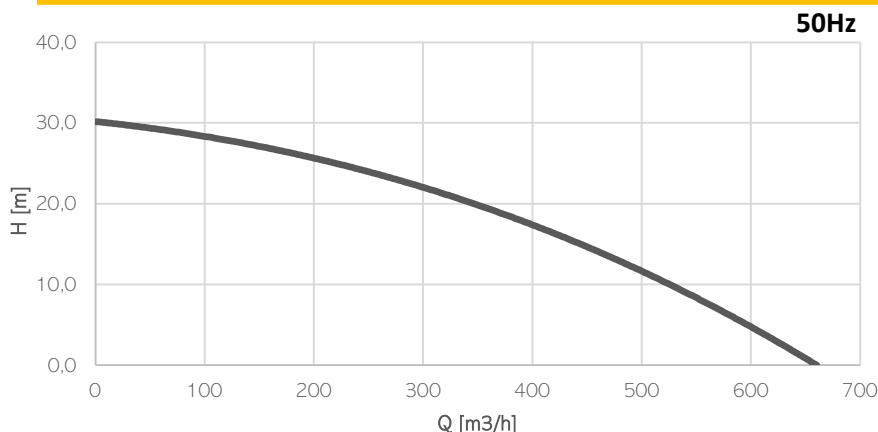

KG
Peso
(cavo escluso)
1060 [kg]
2337 [lb]

Motore elettrico

| Classe di isolamento H

Cavo

| 1 x H07RN-F 4G35 lunghezza 20m

Condizioni Operative

| Max temperatura del liquido 35°C
| Immersione minima 1510 mm

Modello	EL60	
Potenza all'albero [kW HP]	45 60	
Potenza Elettrica [kW HP]	49 66	
Frequenza [Hz]	50	60
Efficienza [%]	52%	60%
Poli	6	6
RPM	980	1176
Tensione [V]	400	460
Assorbimento [A]	88	79
Passaggio Solido [mm in]	60 2.4	
Scarico [DN-PN]	150-10	

Materiali

Parte	Standard
Voluta	Cast Iron EN-GJS500
Corpo	Cast Iron EN-GIL250
Parte di usura	High chrome EN-GJN-HV600 (CH6)
Durezza minima [HB]	550
Albero	Alta resistenza 39NiCrMo3
PH Range	5-10

Tenute e lubrificanti

Versione	EL60	MG	MS
Lato Motore	LABBRO	MECCANICA	MECCANICA
Lato Girante	LABBRO	LABBRO	MECCANICA
Olio	EP320	ISO32	ISO32