

# POMPA ELETTRICA

## EL300

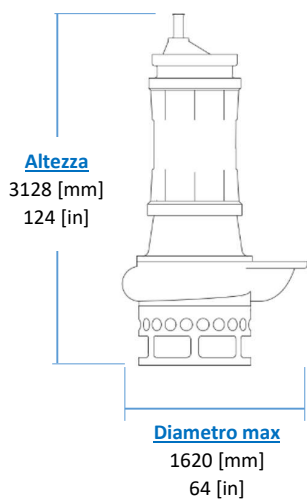
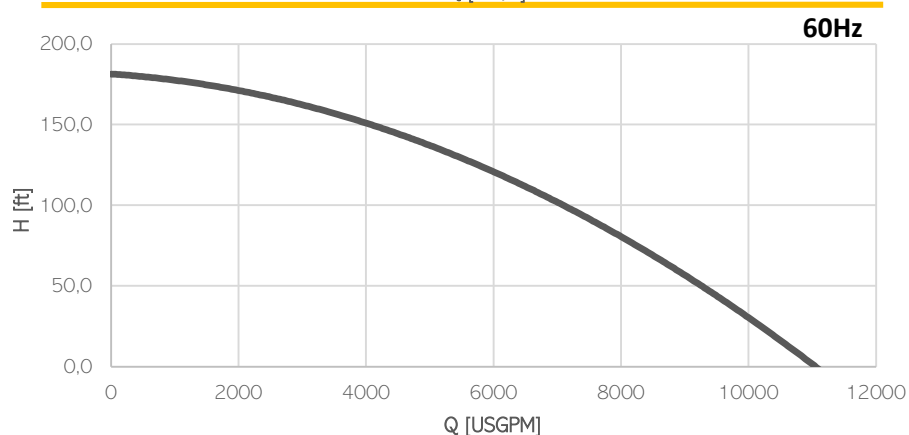
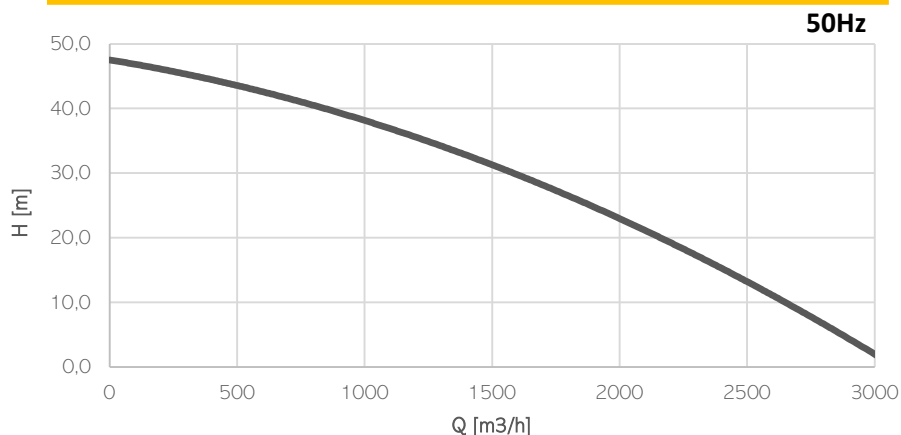

**KG**  
**Peso**  
(cavo escluso)  
**5170 [kg]**  
**11400 [lb]**

### **Motore elettrico**

| Classe di isolamento H

### **Cavo**

| 2 x H07RN-F 4G95 lunghezza 20m

### **Condizioni Operative**

| Max temperatura del liquido 35°C  
| Immersione minima 2900 mm

Modello	EL300	
Potenza all'albero [kW   HP]	240   322	
Potenza Elettrica [kW   HP]	255   342	
Frequenza [Hz]	50	60
Efficienza [%]	60%	60%
Poli	8	8
RPM	745	895
Tensione [V]	400	460
Assorbimento [A]	450	390
Passaggio Solido [mm   in]	120   4,7	
Scarico [DN-PN]	450   PN10	

### **Materiali**

Parte	Standard
Voluta	Cast Iron EN-GJS500
Corpo	Cast Iron EN-GJS500
Parte di usura	High chrome EN-GJN-HV600 (CH6)
Durezza minima [HB]	550
Albero	Alta resistenza 39NiCrMo3
PH Range	5-10

### **Tenute e lubrificanti**

Versione	STANDARD	MG
Lato Motore	LABBRO	MECCANICA
Lato Girante	LABBRO	LABBRO
Olio	EP320	ISO32