

# HYDRAULIC PUMP HY24

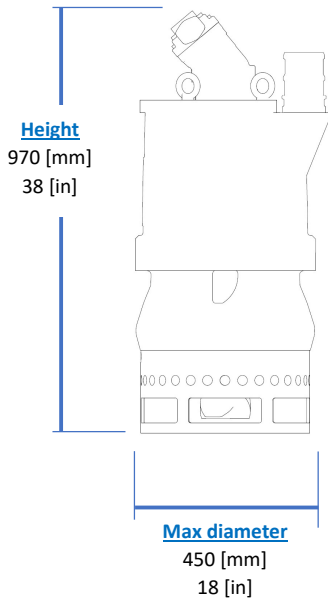
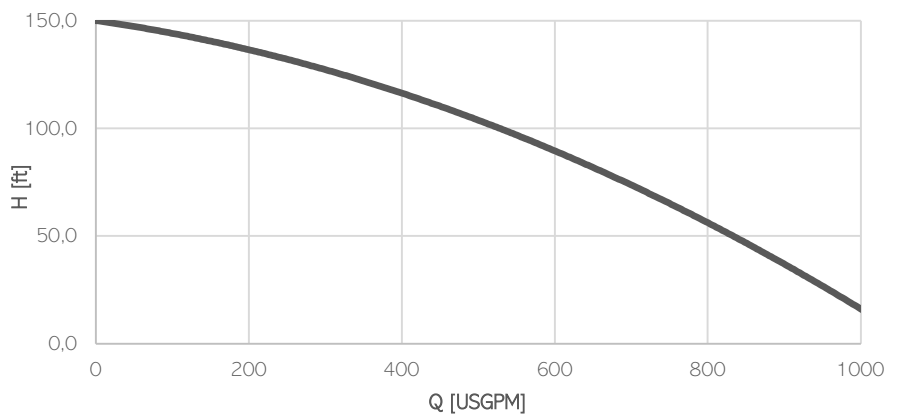
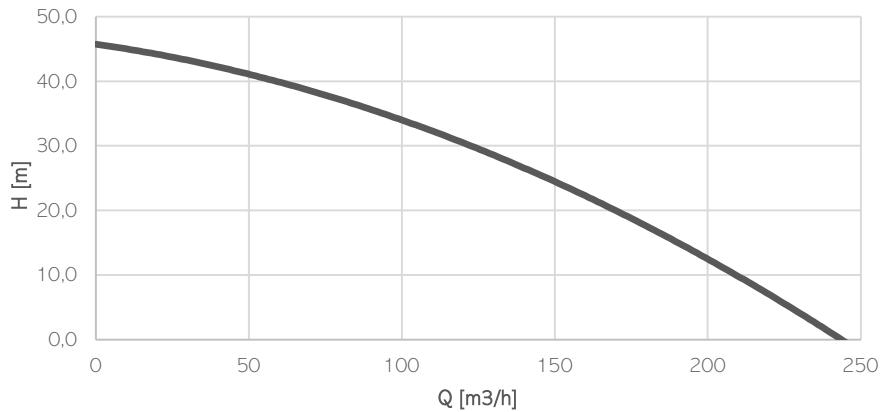

**KG**  
**Weight**  
220 [kg]  
485 [lb]

Model	HY24
Brake Power [kW HP]	24   32.5
Efficiency [%]	44
RPM Max	2000
Motor Displacement [cc]	23
Oil flow rate max [l/min]	46
Nominal pressure [bar]	300
Max pressure [bar]	350
Solid handling [mm in]	25   1
Discharge (Hose adaptor) [mm in]	100   4"

### Materials

Part	Standard
Casing	Cast Iron EN-GJS500
Body	Cast Iron EN-GJS500
Wear Parts	High chrome EN-GJN-HV600 (CH6)
Minimum hardness [HB]	550
Main shaft	High tensile 39NiCrMo3
PH Range	5-10

### Seals and lubricants

Version	STANDARD
Motor Side	MECHANICAL
Impeller Side	MECHANICAL
Oil type	ISO32

### Ports

- | Service line Ports: SAE J518 3/4in
- | Case drain Port: DIN3852 M18x1,5

### Operating Conditions

- | Max liquid temperature 40°C
- | Min Submersion depth 380mm