

ELECTRIC PUMP

EL7.5

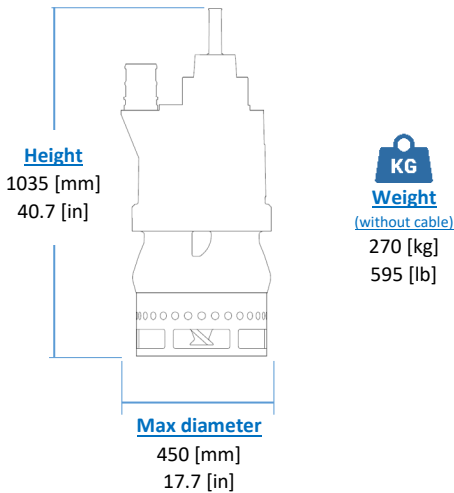
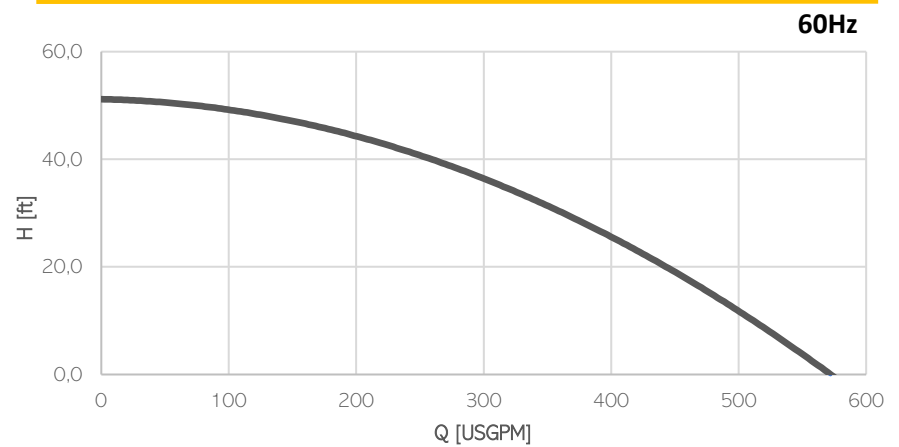
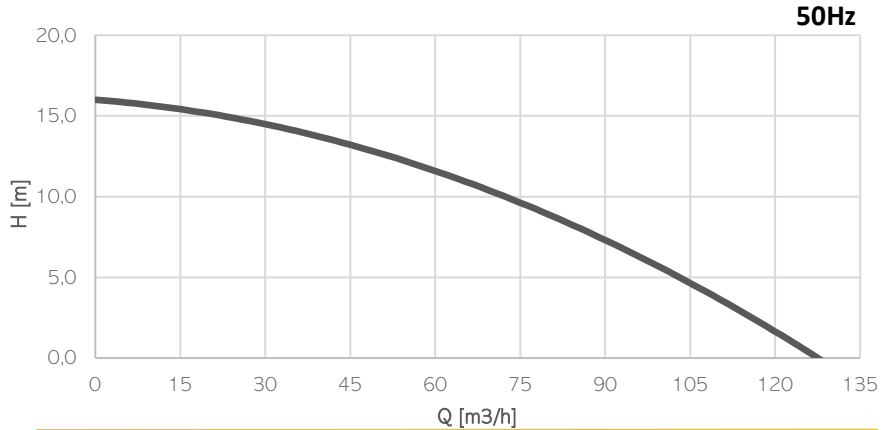

Electrical motor

Insulation class H

Cable

1 x H07RN-F 4G10 length 20m

Operating Conditions

- Max liquid temperature 35°C
- Min Submersion depth 380mm

Model	EL7.5	
Brake Power [kW HP]	5.5 7.4	
Electric Power [kW HP]	6.8 9	
Frequency [Hz]	50	60
Efficiency [%]	32%	32%
Number of Poles	4	4
RPM	1450	1740
Voltage [V]	400	460
Rated Current [A]	12.7	10.9
Solid handling [mm in]	25 1	
Discharge (Hose adaptor) [mm in]	100 4"	

Materials

Part	Standard
Casing	Cast Iron EN-GJS500
Body	Cast Iron EN-GJS500
Wear Parts	High chrome EN-GJN-HV600 (CH6)
Minimum hardness [HB]	550
Main shaft	High tensile 39NiCrMo3
PH Range	5-10

Seals and lubricants

Version	STANDARD
Motor Side	MECHANICAL
Impeller Side	MECHANICAL
Oil type	ISO32