



CABLE DREDGES

DRAGFLOW
ULTIMATE EFFICIENCY

**SUBMERSIBLE
DREDGING PUMPS**



**REMOTE CONTROLLED
DREDGES**



**AMPHIBIOUS
DREDGES**



**CABLE
DREDGES**



DRH: Easy to handle and versatile Cable Dredges

Our Cable dredges (DRH) are successfully used in all those applications where it is necessary to have tools that are manageable and able to work even at great depths.

The small size and modular design allow these dredges to be transported even in remote and difficult to reach locations. Assembly and installation are simple and take only a few hours. These features help to reduce project start-up times and costs.

Our DRH dredges are simple to use: thanks to intuitive controls, they can be managed by a single operator on board.

Available in different versions (with the possibility of hydraulic or electrical power supply), they can be equipped with a wide range of pumps and accessories to perform even in the most difficult situations. The largest model can provide a flow rate of up to 4000 m³/h.

The limited draft and the possibility of rapidly obtaining naval certifications are additional points of strength because they allow DRH to operate in very varied contexts, from artificial ponds to ports, from dams to mining basins.





Main features

- **Easy** to use
- **High productivity**
- Possibility of **working at high depth** with a small hull
- **Maximum flexibility:** each dredge can be equipped with different pump models and numerous accessories
- **Limited draft**
- **Fast delivery times**
- **Speed and cost-effectiveness of transport** thanks to the modular design
- Extremely **fast assembly** and start-up **times**

Main applications

- Cleaning of **canals and rivers**
- Dredging of **ports and marinas**
- Desilting industrial **artificial lakes**
- Dredging of **dam reservoirs**
- Emptying of **mineral tailing ponds**
- Filling of **geotubes**
- Cleaning of **reservoirs** in the food industry
- Removal of **sludge** from industrial or mining processes



Our line of cable dredges is also available in automatic version.



DRH85 | DRH85/160

[hydraulic pump]

electric or diesel power unit

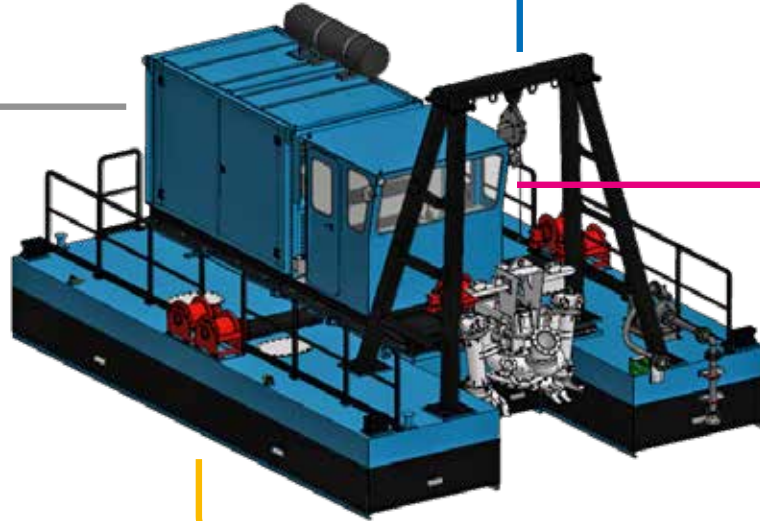

Hydraulic hoist

- Manages the descent and ascent of the pump
- Depth meter



Operator's cabin

- Command and control panel
- Heating and air conditioning
- Ergonomic seat for the operator
- Safety equipment



Power unit

- Soundproof cabin
- Diesel engine or electric motors
- Oil pumps

Winches (x4)

- To move the dredge
- Steel cables up to 210 m
- Possibility of additional propeller for movement

Hull

- Two pontoons 8x1.8x1.25 m with central hull
- Low draft

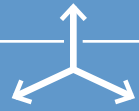

DRH DIMENSIONS SET UP

Length	8 m
Width	6 m
Height	5 m
Weight	30 ton



TRANSPORT

Transportable in 4 containers 40'.



MODULAR DESIGN

Dimensions	Two pontoons 8x1,8x1,25 m with central hull.
Draft	60 cm



RANGE OF DREDGING PUMPS

HY85	MAX FLOW RATE [m ³ /h]: 500 MAX PUMPING DISTANCE [m]: 800 DISCHARGE DIAMETER: DN150 MAX SOLID PASSAGE: 60 mm
HY85HC	MAX FLOW RATE [m ³ /h]: 1000 MAX PUMPING DISTANCE [m]: 500 DISCHARGE DIAMETER: DN250 MAX SOLID PASSAGE: 90 mm
HY85/160	MAX FLOW RATE [m ³ /h]: 600 MAX PUMPING DISTANCE [m]: 1500 DISCHARGE DIAMETER: DN250 MAX SOLID PASSAGE: 60 mm
HY85/160HC	MAX FLOW RATE [m ³ /h]: 1000 MAX PUMPING DISTANCE [m]: 700 DISCHARGE DIAMETER: DN250 MAX SOLID PASSAGE: 90 mm

Performance will depend on the actual site conditions and duty point.

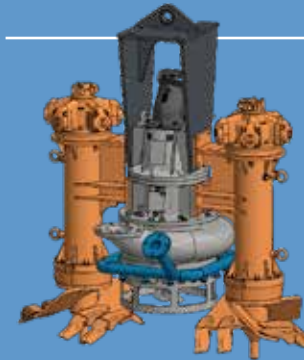

ACCESSORIES

Excavators

- Motor power: 14.5 kW
- Replaceable teeth
- Hydraulic motor with radial pistons
- Oil flow rate: 35 l/min each
- Weight : 500 kg
- Speed: 50 r.p.m.
- Torque: 2.6 kNm
- Rotation in both directions

Integrated jet ring system

- Thanks to the high-pressure water jets, it allows to disintegrate the material and have a higher concentration of solids in the mixture
- Flow rate: 60-200 m³/h
- Pressure: 6-7 bar
- Power supply: high pressure horizontal pump

Propeller

- To move and rotate the dredge
- Hydraulic driven
- Maneuverable from the cabin

ACCESSORIES	STANDARD	FULL OPTIONAL	HIGH DEPTH
Winches	✓	✓	✓
Hoist	✓	✓	✓
Operator's cabin	✓	✓	✓
Control panel	✓	✓	✓
Depth meter	✓	✓	✓
GPS		✓	✓
Propeller		✓	✓
Hose reel		✓	✓
Bathymetry system		✓	✓
Pressure compensator			✓

DRH85 | DRH85/160

DRH85e | DRH 85/160e

[electric pump]

generator and/or transformer set

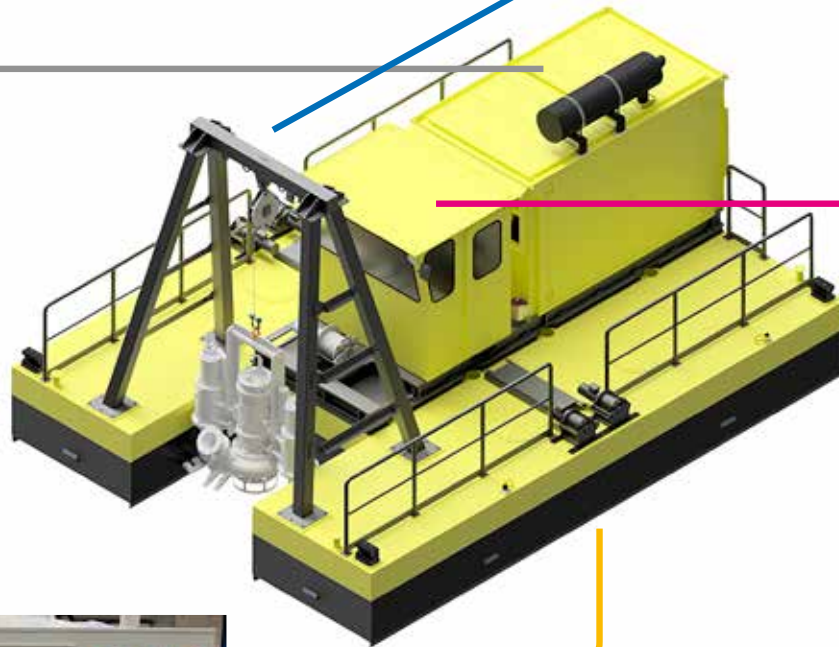

Electric hoist

- Manages the descent and ascent of the pump
- Depth meter



Operator's cabin

- Command and control panel
- Heating and air conditioning
- Ergonomic seat for the operator
- Safety equipment



Generator and/or transformer set

- Soundproof cabin
- Diesel engines

Winches (x4)

- To move the dredge
- Steel cables up to 210 m
- Possibility of additional propeller for movement

Hull

- Two pontoons 8x1.8x1.25 m with central hull
- Low draft



RANGE OF DREDGING PUMPS

- EL60*** MAX FLOW RATE [m³/h]: 500
 MAX PUMPING DISTANCE [m]: 500
 DISCHARGE DIAMETER: DN150
 MAX SOLID PASSAGE: 60 mm
- EL60HC*** MAX FLOW RATE [m³/h]: 700
 MAX PUMPING DISTANCE [m]: 300
 DISCHARGE DIAMETER: DN250
 MAX SOLID PASSAGE: 90 mm
- EL1204*** MAX FLOW RATE [m³/h]: 600
 MAX PUMPING DISTANCE [m]: 1000
 DISCHARGE DIAMETER: DN150
 MAX SOLID PASSAGE: 60 mm
- EL1204HC***
 MAX FLOW RATE [m³/h]: 700
 MAX PUMPING DISTANCE [m]: 500
 DISCHARGE DIAMETER: DN250
 MAX SOLID PASSAGE: 90 mm

Performance depends on the actual site conditions and duty point.

* = can mount side excavators

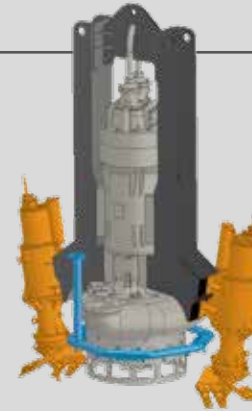

ACCESSORIES

Excavators

- Motor power: 9 kW
- Replaceable teeth
- Electric motor
- Weight: 800 kg
- Speed: 25 r.p.m.
- Torque: 3,2 kNm
- Rotation in both directions

Integrated jet ring system

- Thanks to high pressure water jets, allows to disintegrate the material and have a higher concentration of solid in the mixture
- Flow rate: 60-200 m³/h
- Pressure: 6-7 bar
- Power supply: high pressure horizontal pump

Propeller

- To move and rotate the dredge
- Hydraulic driven
- Maneuverable from the cabin

ACCESSORIES	STANDARD	FULL OPTIONAL	HIGH DEPTH
Winches	✓	✓	✓
Hoist	✓	✓	✓
Operator's cabin	✓	✓	✓
Control panel	✓	✓	✓
Depth meter	✓	✓	✓
GPS		✓	✓
Propeller		✓	✓
Hose reel		✓	✓
Bathymetry system		✓	✓
Pressure compensator			✓

THE SAME HULL OF THE MODELS DRH85 AND DRH85/160 CAN BE EQUIPPED WITH ELECTRIC GENSET AND ELECTRIC PUMPS

ZERO-EMISSION DREDGER:

WHEN ELECTRICITY IS SUPPLIED FROM A LOCAL RENEWABLE SOURCE

DRH85e | DRH 85/160e

DRH300 | DRH400 | DRH600

[hydraulic pump]

powerpack with diesel or electric motor



Hydraulic hoist

- Manages the descent and ascent of the pump
- Depth meter



Operator's cabin

- Command and control panel
- Heating and air conditioning
- Ergonomic seat for the operator
- Safety equipment



Power unit

- Soundproof cabin
- Diesel or electric motors
- Oil pumps

Winches (x4)

- To move the dredge
- Steel cables up to 210 m
- Possibility of additional propeller for movement

Hull

- Two pontoons 11.5x1.8x1.8 m and central frame
- Low draft

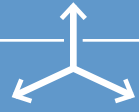

DRH DIMENSIONS SET UP

Length	11.5 m
Width	8 m
Height	7.5 m
Weight	45/60 ton



TRANSPORT

Transportable in 5 containers 40'.



MODULAR DESIGN

Dimensions	Two pontoons 11.5x1.8x1.8 m and central frame.
Draft	80-90 cm



RANGE OF DREDGING PUMPS

HY300	MAX FLOW RATE [m ³ /h]: 2000 MAX PUMPING DISTANCE [m]: 1000 DISCHARGE DIAMETER: DN250 MAX SOLID PASSAGE: 120 mm
HY400	MAX FLOW RATE [m ³ /h]: 2000 MAX PUMPING DISTANCE [m]: 2000 DISCHARGE DIAMETER: DN300-350 MAX SOLID PASSAGE: 120 mm
HY400HC	MAX FLOW RATE [m ³ /h]: 3000 MAX PUMPING DISTANCE [m]: 1000 DISCHARGE DIAMETER: DN450 MAX SOLID PASSAGE: 120 mm
HY600	MAX FLOW RATE [m ³ /h]: 2500 MAX PUMPING DISTANCE [m]: 3000 DISCHARGE DIAMETER: DN350-400 MAX SOLID PASSAGE: 120 mm
HY600HC	MAX FLOW RATE [m ³ /h]: 4000 MAX PUMPING DISTANCE [m]: 1000 DISCHARGE DIAMETER: DN450 MAX SOLID PASSAGE: 120 mm

Performance depends on actual site conditions and duty point



ACCESSORIES

Excavators

- Motor power: 25 kW
- Replaceable teeth
- Hydraulic motor with radial pistons
- Oil flow rate: 60 l/min each
- Weight : 600 kg
- Speed: 50 r.p.m.
- Torque: 4.5 kNm
- Rotation in both directions

Integrated jet ring system

- Thanks to the high-pressure water jets, it allows to disintegrate the material and have a higher concentration of solid in the mixture
- Flow rate: 100-200 m³/h
- Pressure: 6-7 bar
- Power supply: high pressure horizontal pump

Propeller

- To move and rotate the dredge
- Hydraulic driven
- Maneuverable from the cabin

ACCESSORIES	STANDARD	FULL OPTIONAL	HIGH DEPTH
Winches	✓	✓	✓
Hoist	✓	✓	✓
Operator's cabin	✓	✓	✓
Control panel	✓	✓	✓
Depth meter	✓	✓	✓
GPS		✓	✓
Propeller		✓	✓
Hose reel		✓	✓
Bathymetry system		✓	✓
Pressure compensator			✓

DRH300 | DRH400 | DRH600

DRH300e

[electric pump]

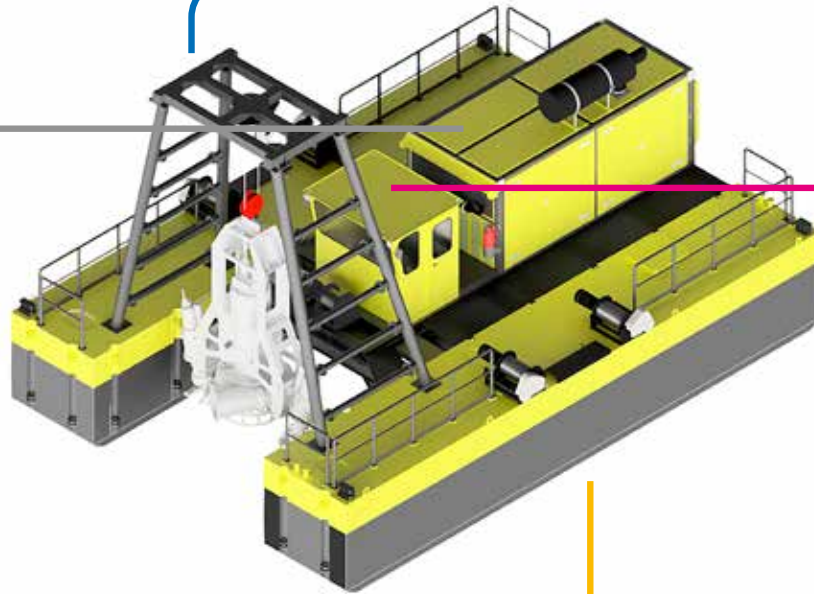

Electric hoist

- Manages the descent and ascent of the pump
- Depth meter



Operator's cabin

- Command and control panel
- Heating and air conditioning
- Ergonomic seat for the operator
- Safety equipment



Generator or transformer set

- Soundproof cabin
- Diesel engines

Winches (x4)

- To move the dredge
- Steel cables up to 210 m
- Possibility of additional propeller for movement

Hull

- Two pontoons 11,5x1,8x1,8 m with a central frame
- Low draft



RANGE OF DREDGING PUMPS

Performance depends on the actual site conditions and duty point.

- EL110*** MAX FLOW RATE [m³/h]: 600
MAX PUMPING DISTANCE [m]: 1000
DISCHARGE DIAMETER: DN200
MAX SOLID PASSAGE: 60 mm
- EL150*** MAX FLOW RATE [m³/h]: 1700
MAX PUMPING DISTANCE [m]: 600
DISCHARGE DIAMETER: DN250
MAX SOLID PASSAGE: 120 mm
- EL180*** MAX FLOW RATE [m³/h]: 1000
MAX PUMPING DISTANCE [m]: 900
DISCHARGE DIAMETER: DN200-250
MAX SOLID PASSAGE: 60 mm
- EL300*** MAX FLOW RATE [m³/h]: 2000
MAX PUMPING DISTANCE [m]: 1000
DISCHARGE DIAMETER: DN250
MAX SOLID PASSAGE: 120 mm
- EL300HC** MAX FLOW RATE [m³/h]: 3000
MAX PUMPING DISTANCE [m]: 700
DISCHARGE DIAMETER: DN450
MAX SOLID PASSAGE: 120 mm

* = can mount side excavators

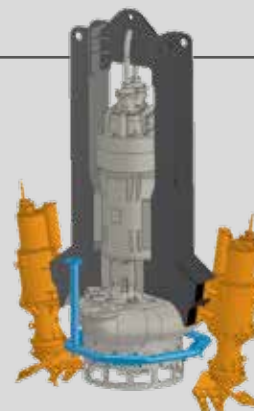

ACCESSORIES

Excavators

- Motor power: 9 kW
- Replaceable teeth
- Electric motor
- Weight: 800 kg
- Speed: 25 r.p.m.
- Torque: 3,2 kNm
- Rotation in both directions

Integrated jet ring system

- Thanks to high pressure water jets, allows to disintegrate the material and have a higher concentration of solid in the mixture
- Flow rate: 60-200 m³/h
- Pressure: 6-7 bar
- Power supply: high pressure horizontal pump

Propeller

- To move and rotate the dredge
- Hydraulic driven
- Maneuverable from the cabin

THE SAME HULL OF MODELS DRH300, DRH400 AND DRH600 CAN BE EQUIPPED WITH ELECTRIC GENSET AND ELECTRIC PUMPS

ZERO-EMISSION DREDGER:

WHEN ELECTRICITY IS SUPPLIED FROM A LOCAL RENEWABLE SOURCE

ACCESSORIES	STANDARD	FULL OPTIONAL	HIGH DEPTH
Winches	✓	✓	✓
Hoist	✓	✓	✓
Operator's cabin	✓	✓	✓
Control panel	✓	✓	✓
Depth meter	✓	✓	✓
GPS		✓	✓
Propeller		✓	✓
Hose reel		✓	✓
Bathymetry system		✓	✓
Pressure compensator			✓

DRH300e

Dragflow monitoring system

Dragflow has developed a monitoring system for the full range of dredges that allows operators and project managers to keep track of key indicators of a project such as placement, area coverage, and more. The information is collected by a series of sensors on board and saved on a cloud-based system accessible to operators on the dredges and offsite project managers. This telemetry package also allows remote diagnosis and downtime prevention that greatly increases efficiency of the overall dredging operation.

The Dragflow monitoring system is customized for each application and can include following accessories:

Positioning and Bathymetry

- **GPS System:** precise mapping and positioning within the dredging area for effective coverage and better planning. The system can be combined with sensors such as Encoder pulley, flow meter, densimeter and more for data crossing.
- **Echosounder:** the serial interface can connect to the GPS system via RS232 communication, and elaborate georeferenced maps, useful to make the work more easy and accurate.

Work parameters

- **Flowmeter:** the electromagnetic flow meter provides flow measurements in real time for the operator. In combination with the densimeter, it is possible to quantify the volume of material actually removed.
- **Density meter:** provides real-time density measurements in the discharge pipe for all types of solids. The meter uses ultrasonic technology to measure density and it is specifically designed for dredging and mineral applications.

Working depth meter

In order to determine the location of the dredging pump during operations, depending on the application Dragflow dredges can be equipped with encoder pulleys or piezoresistive transducers to provide real-time information to the operator.



DREDGING APPLICATIONS:

**PORT
DREDGING**





DREDGING APPLICATIONS:

**PORT
DREDGING**

MINING APPLICATIONS:

**DREDGING
IN MINING DAM**





DREDGING APPLICATIONS:

**SAND
EXTRACTION**

DREDGING APPLICATIONS:

DREDGING IN DAM





DREDGING APPLICATIONS:

**PORT
DREDGING**

DREDGING APPLICATIONS:

**SAND
EXTRACTION**





MINING APPLICATIONS:

**DREDGING
IN MINING DAM**





Dragflow S.r.l.

Head Office

Via Paesa
46048 Roverbella (MN) - Italy
tel. +39 0376 1685400
fax +39 0376 1685499
info@dragflow.it
www.dragflow.it



Dragflow



dragflowdredge



Dragflow



dragflowdredge



DRAGFLOW S.r.l.



Dragflow S.r.l.
Head Office
Via Paesa
46048 Roverbella
(MN) - Italy
tel. +39 0376 1685400
fax +39 0376 1685499
info@dragflow.it
www.dragflow.it