

POMPA ELETTRICA EL604SHH

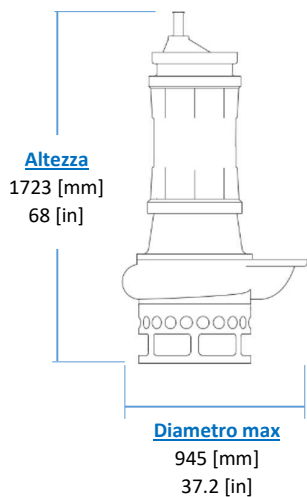
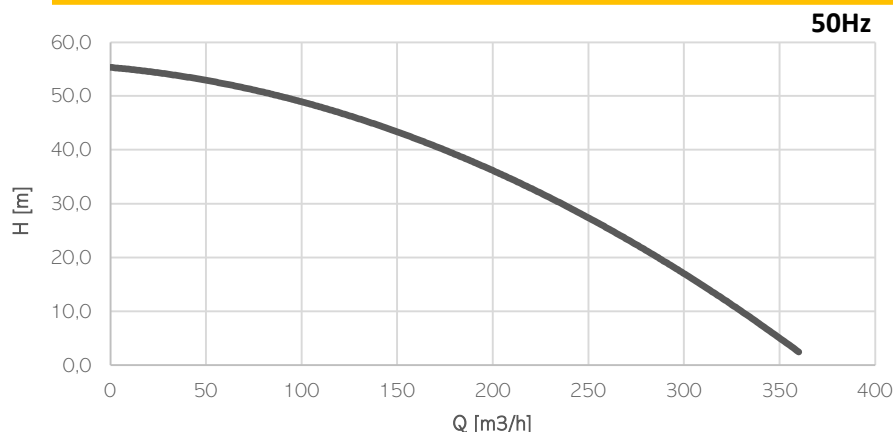

KG
Peso
(cavo escluso)
1250 [kg]
2755 [lb]

Motore elettrico

| Classe di isolamento H

Cavo

| 1 x H07RN-F 4G35 lunghezza 20m

Condizioni Operative

| Max temperatura del liquido 35°C
| Immersione minima 1510 mm

Modello	EL604SHH	
Potenza all'albero [kW HP]	90 120	
Potenza Elettrica [kW HP]	96 128	
Frequenza [Hz]	50	60
Efficienza [%]	48%	47%
Poli	4	4
RPM	1480	1776
Tensione [V]	400	460
Assorbimento [A]	158	141
Passaggio Solido [mm in]	35 1.4	
Scarico [DN-PN]	100-10	

Materiali

Parte	Standard
Voluta	Cast Iron EN-GJS800
Corpo	Cast Iron EN-GIL250
Parte di usura	High chrome EN-GJN-HV600 (CH6)
Durezza minima [HB]	550
Albero	Alta resistenza 39NiCrMo3
PH Range	5-10

Tenute e lubrificanti

Versione	-	MG	MS
Lato Motore	-	MECCANICA	MECCANICA
Lato Girante	-	LABBRO	MECCANICA
Olio	-	ISO32	ISO32