

ELECTRIC PUMP EL110S

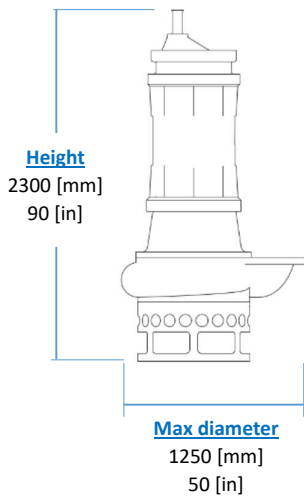
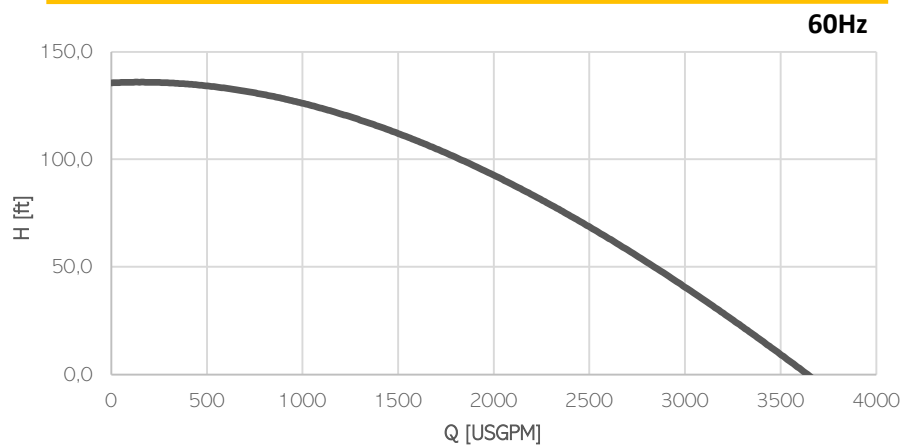
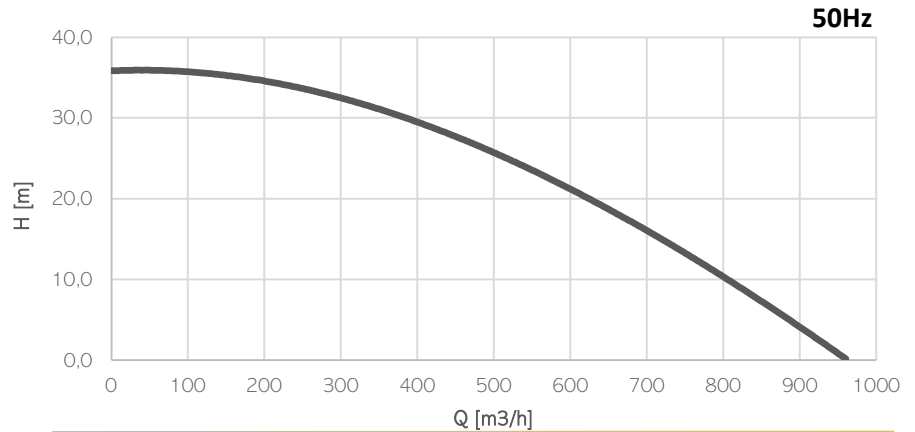

KG
Weight
(without cable)
2450 [kg]
5400 [lb]

Electrical motor

Insulation class H

Cable

1 x H07RN-F 4G95 length 20m

Operating Conditions

- Max liquid temperature 35°C
- Min Submersion depth 1820 mm

Model	EL110S	
Brake Power [kW HP]	110 150	
Electric Power [kW HP]	120 160	
Frequency [Hz]	50	60
Efficiency [%]	56%	55%
Number of Poles	8	8
RPM	745	894
Voltage [V]	400	460
Rated Current [A]	220	190
Solid handling [mm in]	60 2.4	
Discharge [DN-PN]	200-10	

Materials

Part	Standard
Casing	Cast Iron EN-GJS500
Body	Cast Iron EN-GIL250
Wear Parts	High chrome EN-GJN-HV600 (CH6)
Minimum hardness [HB]	550
Main shaft	High tensile 39NiCrMo3
PH Range	5-10

Seals and lubricants

Version	-	-	MS
Motor Side	-	-	MECHANICAL
Impeller Side	-	-	MECHANICAL
Oil type	-	-	ISO32