

# POMPA ELETTRICA EL300HC

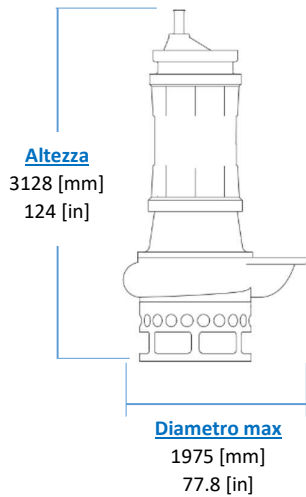
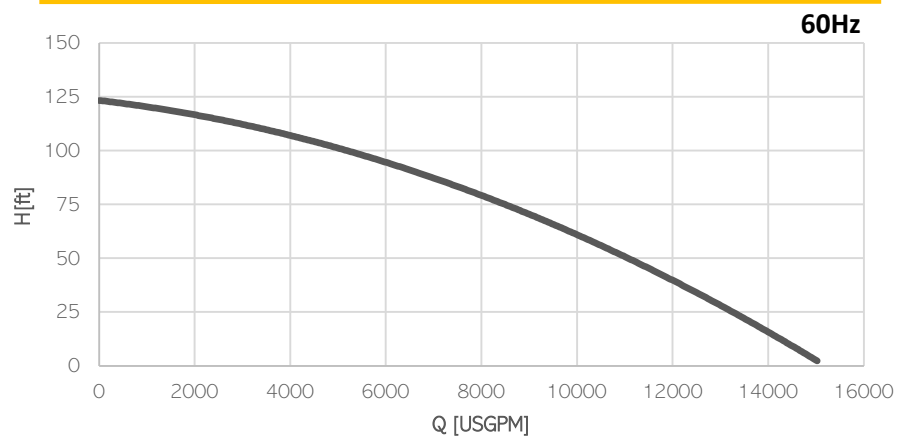
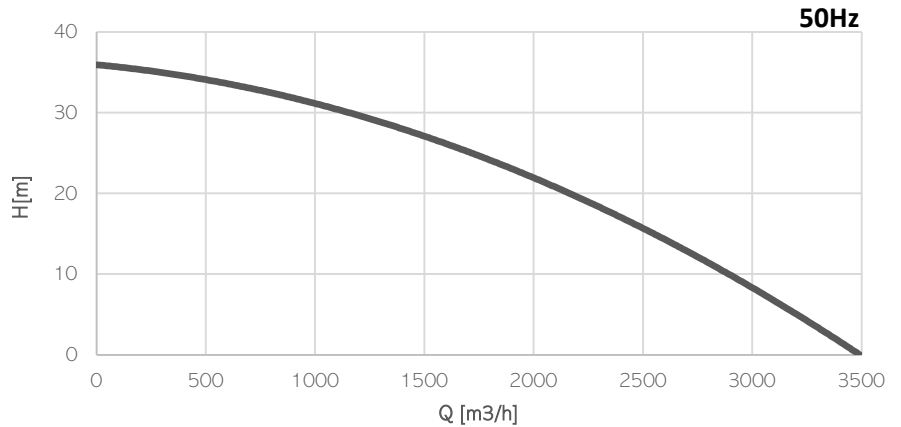

**KG**  
**Peso**  
(cavo escluso)  
5420 [kg]  
12000 [lb]

## Motore elettrico

| Classe di isolamento H

## Cavo

| 2 x H07RN-F 4G95 lunghezza 20m (IEC 60245-4)

## Condizioni Operative

| Max temperatura del liquido 35°C  
| Immersione minima 2900mm

Modello	EL300 HC	
Potenza all'albero [kW   HP]	240   322	
Potenza Elettrica [kW   HP]	255   342	
Frequenza [Hz]	50	60
Efficienza [%]	64%	63%
Poli	8	8
RPM	745	895
Tensione [V]	400	460
Assorbimento [A]	450	390
Passaggio Solido [mm   in]	120   4,7	
Scarico [DN   PN]	450   PN10	

## Materiali

Parte	Standard
Voluta	Cast Iron EN-GJS500
Corpo	Cast Iron EN-GJS500
Parte di usura	High chrome EN-GJN-HV600 (CH6)
Durezza minima [HB]	550
Albero	Alta resistenza 39NiCrMo3
PH Range	5-10

## Tenute e lubrificanti

Versione	STANDARD	MG
Lato Motore	LABBRO	MECCANICA
Lato Girante	LABBRO	LABBRO
Olio	EP320	ISO32