

HYDRAULIC PUMP HY400HC

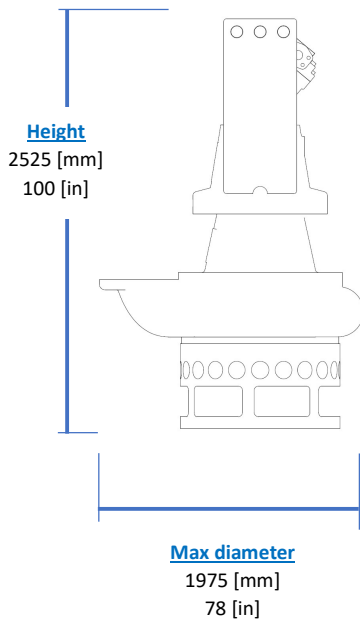
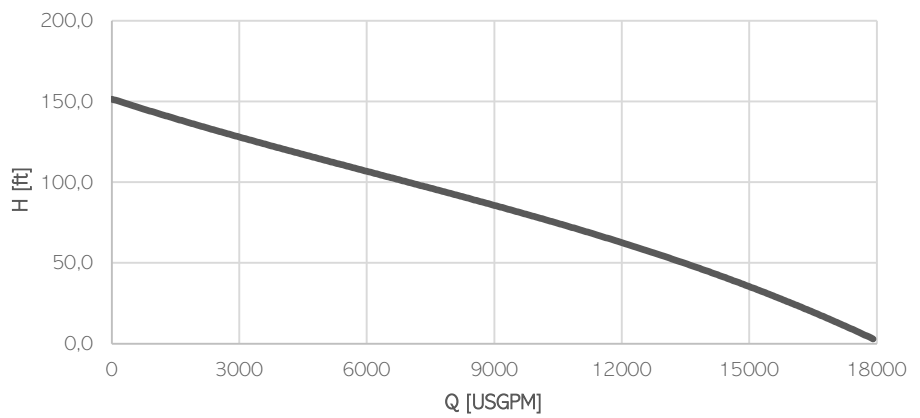
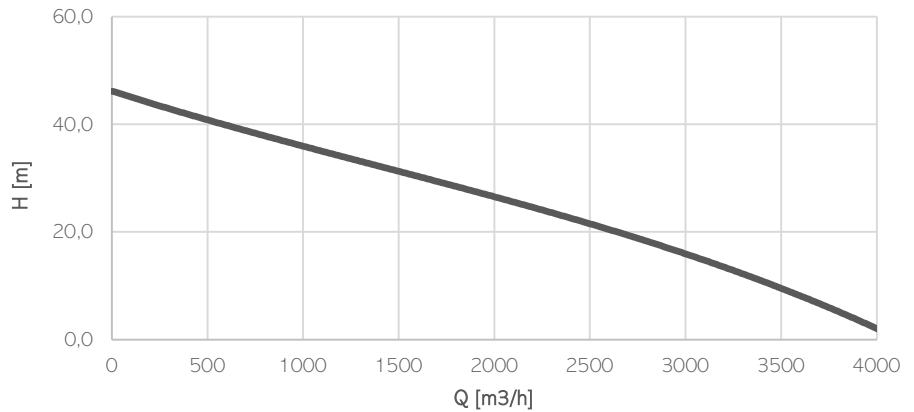

KG
Weight
4500 [kg]
9920 [lb]

Ports

- Service line Ports: SAE J518 1 1/4in
- Case drain Port: DIN3852 M33x2

Operating Conditions

- Max liquid temperature 40°C
- Min Submersion depth 1400mm

Model	HY400
Brake Power [kW HP]	300 400
Efficiency [%]	60
RPM Max	850
Motor Displacement [cc]	710
Oil flow rate max [l/min]	605
Nominal pressure [bar]	300
Max pressure [bar]	350
Solid handling [mm in]	120 4.7
Discharge [DN PN]	450 PN10

Materials

Part	Standard
Casing	Cast Iron EN-GJS500
Body	Cast Iron EN-GJS500
Wear Parts	High chrome EN-GJN-HV600 (CH6)
Minimum hardness [HB]	550
Main shaft	High tensile 39NiCrMo3
PH Range	5-10

Seals and lubricants

Version	HY600HC	MG
Motor Side	LIPS	MECHANICAL
Impeller Side	LIPS	LIPS
Oil type	EP320	ISO32