

Electric pump

EL110SA/B

PUMP SPECIFICATIONS	Mod. A	Mod. B
Capacity [m ³ /h]	350	450
Head [m]	30	27.5
Impeller diameter [mm]/type	637/3 blades closed	
Flanged bore size [DN.../PN...]	DN200/PN10	DN250/PN10
Cross section diameter [mm]	60	
Weight (without cable) [kg]	2700	2750

ELECTRIC MOTOR	
Power [kW-HP]	110-150
Voltage [V]/Current [A]	400/220
Phases/Poles/Frequency [Hz]	3/8/50
Speed [RPM]	740
Insulation class	H
Power cable 20m (IEC 60245- 4)	H07RN-F 4G95

MATERIALS	
Casing	Spheroidal cast iron EN-GJS-500-7 (EN 1563)
Motor housing	Cast iron EN-GJL-250 (EN 1561)
Wear parts	High chrome EN-GJN-HV600 (XCr18) (EN 12513)
Main shaft	High tensile steel 39NiCrMo3 (AISI 9840)

SEALS / LUBRICANT	
Motor side seals	1 mechanical seal (silicon carbide in oil bath)
Impeller side seals	1 mechanical seal (silicon carbide in oil bath) + 2 lip seal (1 BUNA + 1 TPU)
Oil type	ISO 320

DIMENSIONS [mm]							
H	W	D	F	H1	A	B	C
2150	1260	1080	765	1800	500	590	520

PERFORMANCE CURVES

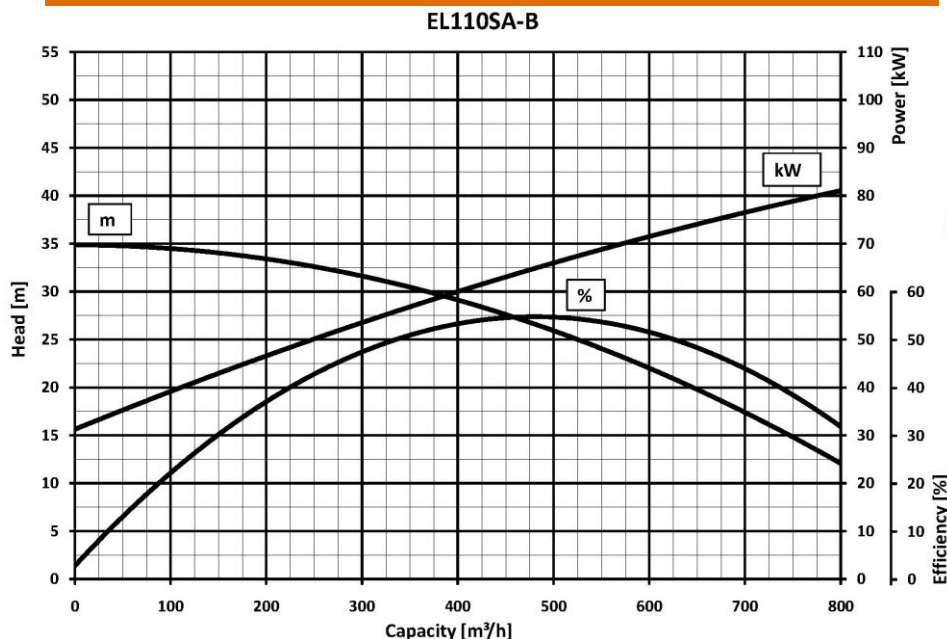

We reserve the right to make changes without notice

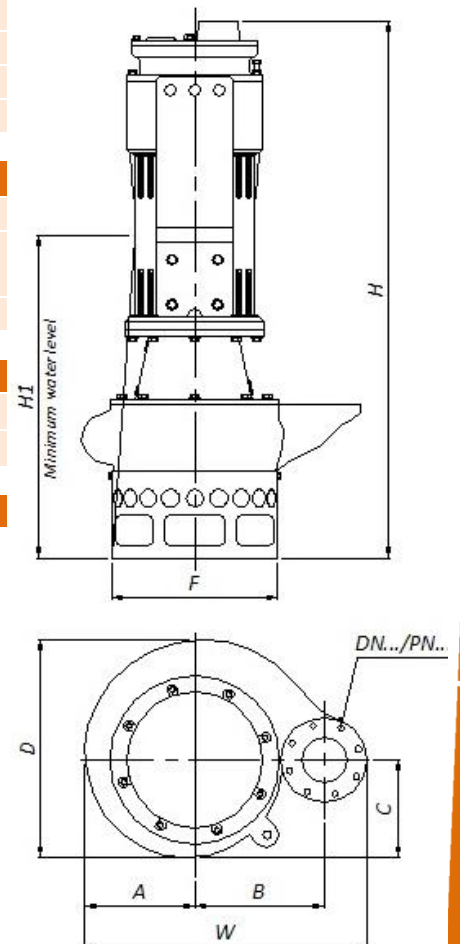

EL110SA-B

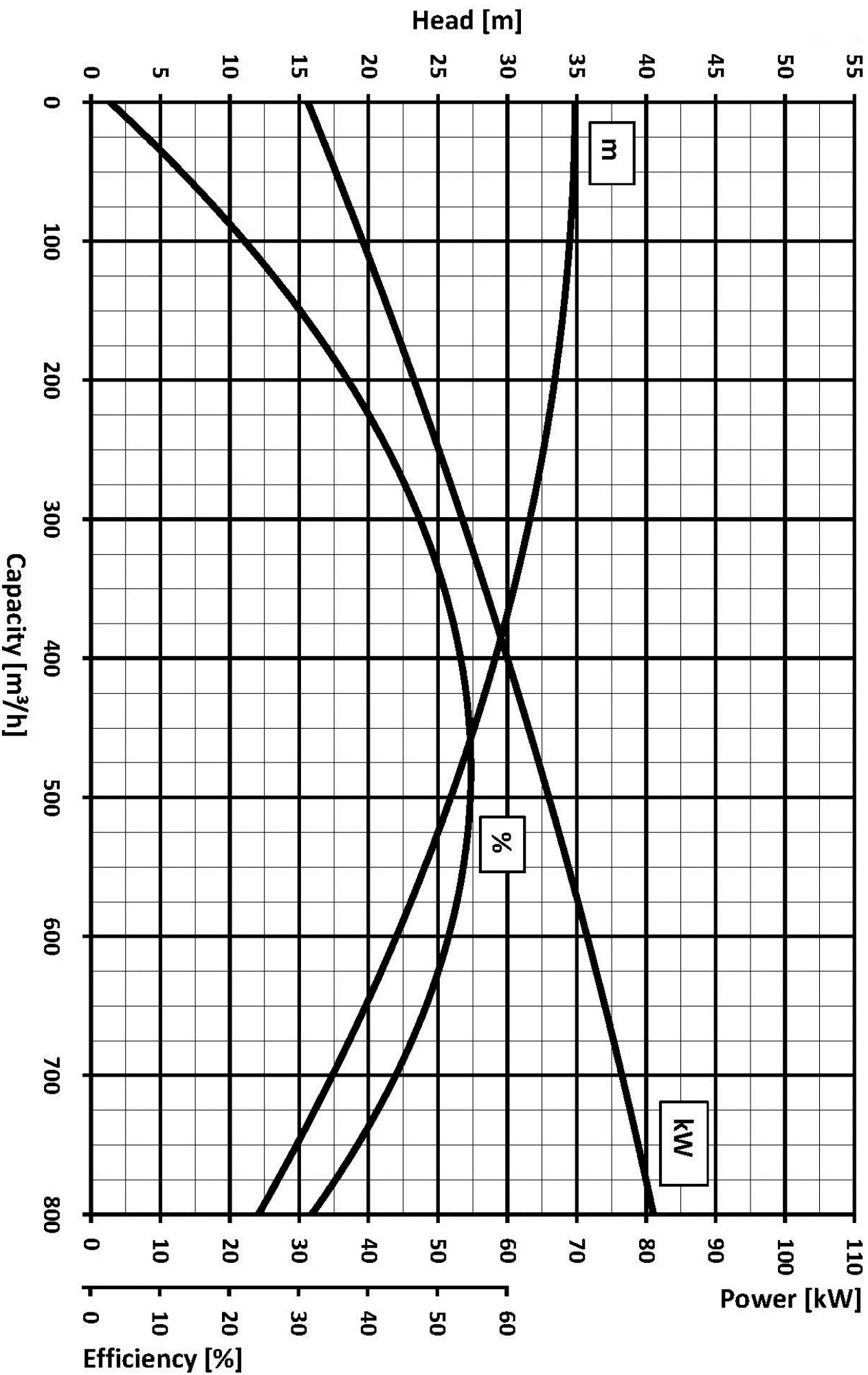

We reserve the right to make changes without notice